

Торцеватель для толстостенных стальных труб с P3-PG-250-II v010224 (ISY-250-II)

sto-ipm.ru

AOTAI MACHINE MANUFACTURING CO., LTD

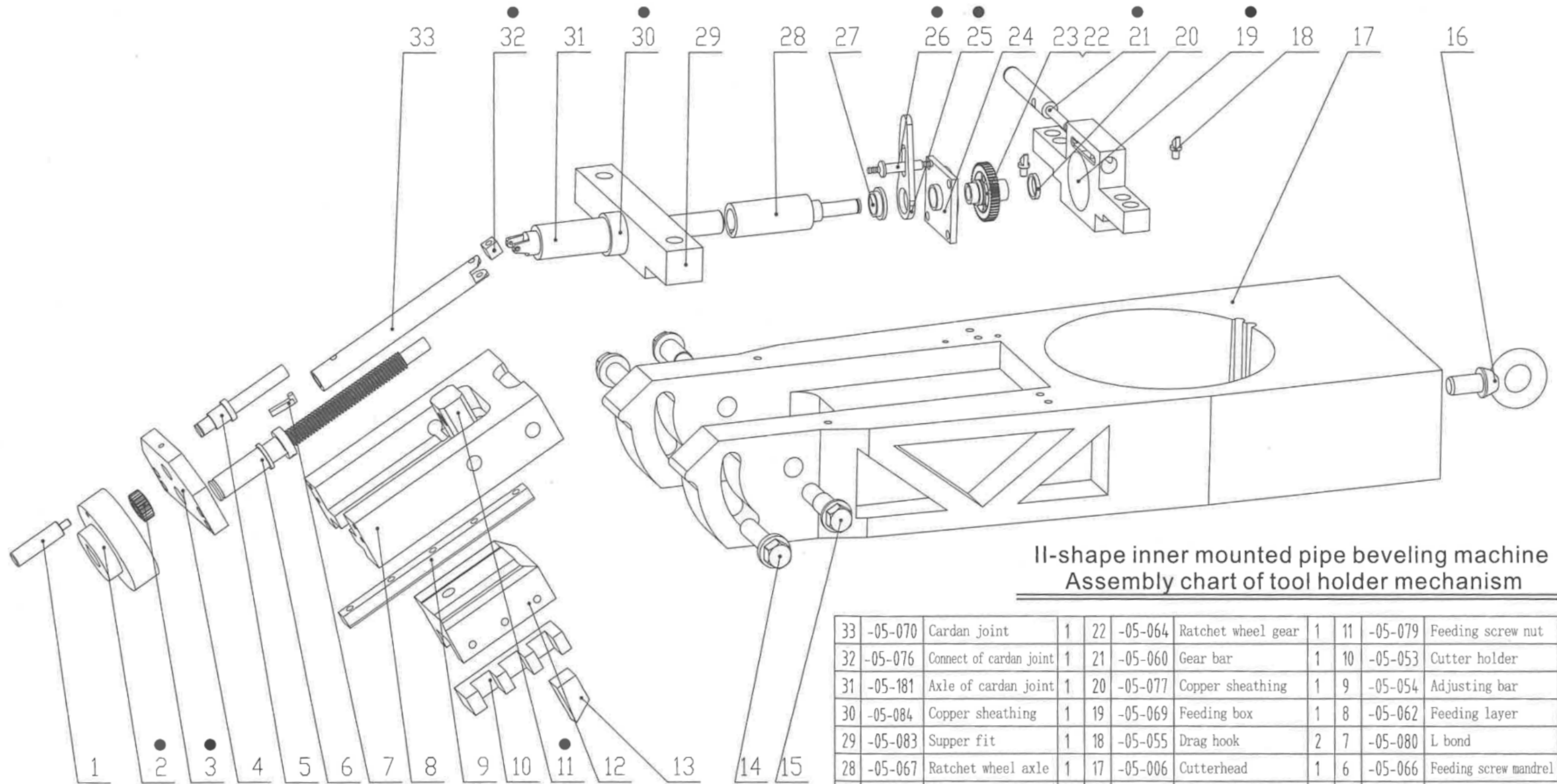

Note: belt ● is the oil filling place

II-shape inner mounted pipe beveling machine
Assembly chart of tool holder mechanism

33	-05-070	Cardan joint	1	22	-05-064	Ratchet wheel gear	1	11	-05-079	Feeding screw nut	1
32	-05-076	Connect of cardan joint	1	21	-05-060	Gear bar	1	10	-05-053	Cutter holder	1
31	-05-181	Axle of cardan joint	1	20	-05-077	Copper sheathing	1	9	-05-054	Adjusting bar	1
30	-05-084	Copper sheathing	1	19	-05-069	Feeding box	1	8	-05-062	Feeding layer	1
29	-05-083	Supper fit	1	18	-05-055	Drag hook	2	7	-05-080	L bond	1
28	-05-067	Ratchet wheel axle	1	17	-05-006	Cutterhead	1	6	-05-066	Feeding screw mandrel	1
27	-05-078	Copper sheathing	1	16		Flying ring	1	5	-05-065	Feeding link rod	1
26	-05-073	Pin bond	1	15	-05-056	Cutterhead bolt (01)	2	4	-05-081	Shell cover of feeding	1
25	-05-075	Butting block	1	14	-05-057	Cutterhead bolt (02)	2	3	-05-071	Feeding gear	1
24	-05-072	Feeding box cover	1	13		Beveling tool	1	2	-05-068	Feeding hand wheel	1
23	-05-059	Ratchet wheel axle		12	-05-058	Blade carrier	1	1	-05-016	Turn hand shank	1
S.N.	CODE	NAME	QTY	S.N.	CODE	NAME	QTY	S.N.	CODE	NAME	QTY